

**Detalhe 01 - Banco 01**

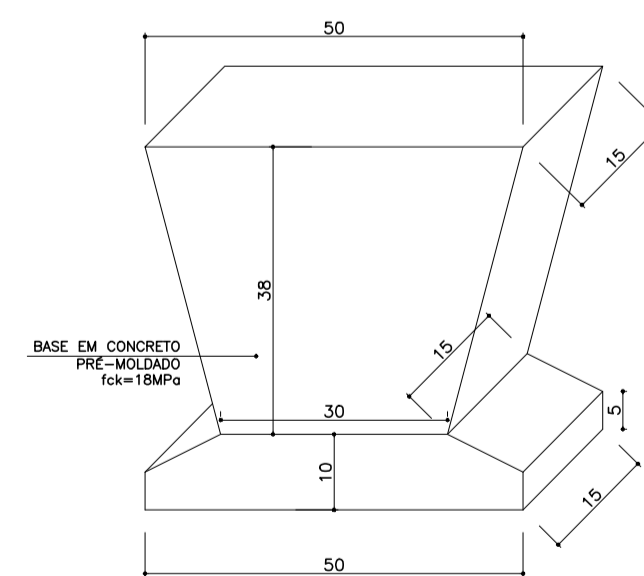

**Detalhe 02 - Banco 02**

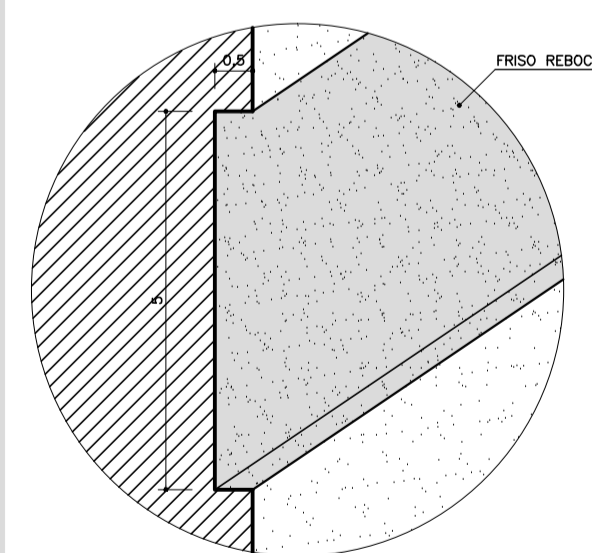
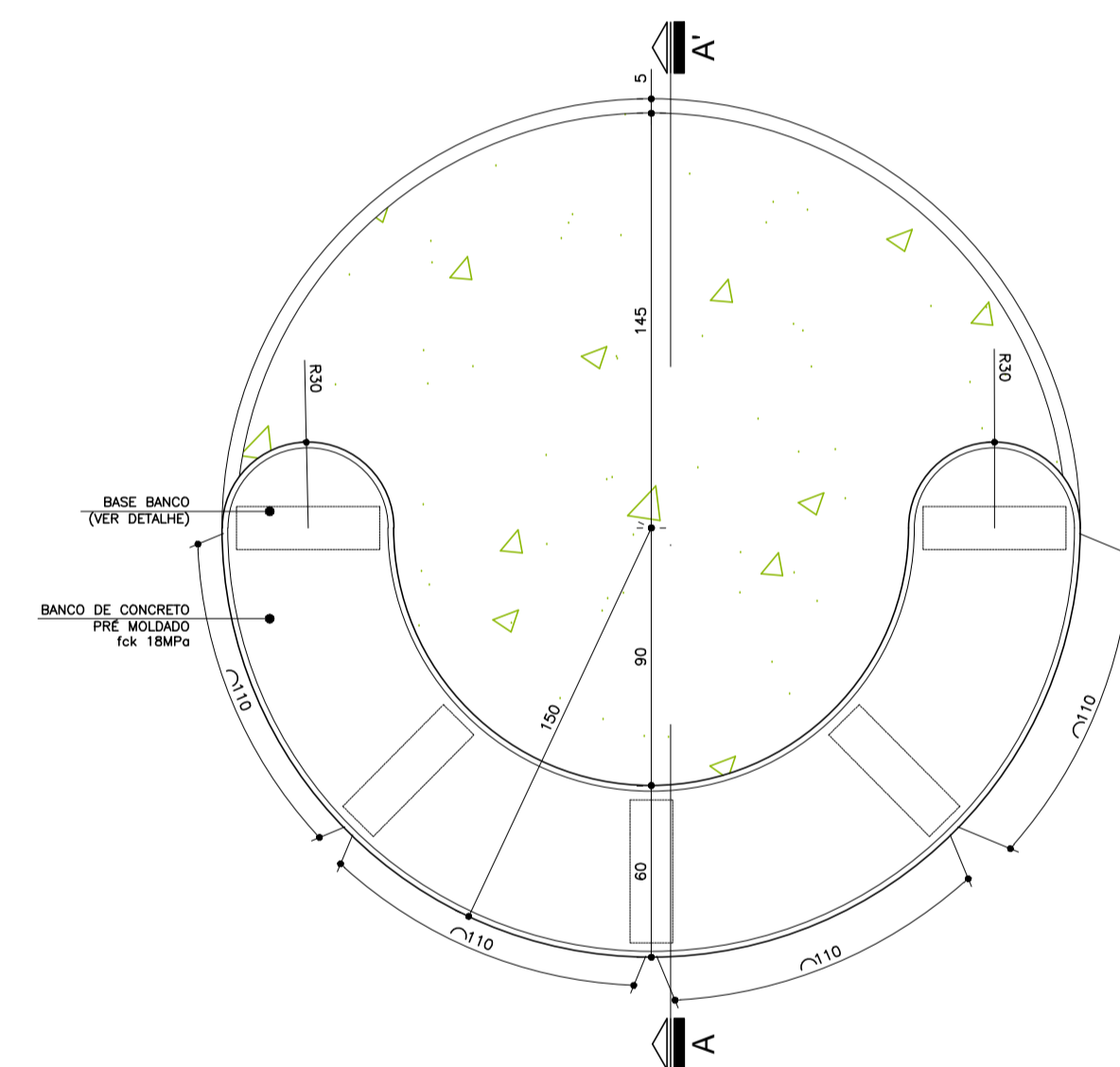
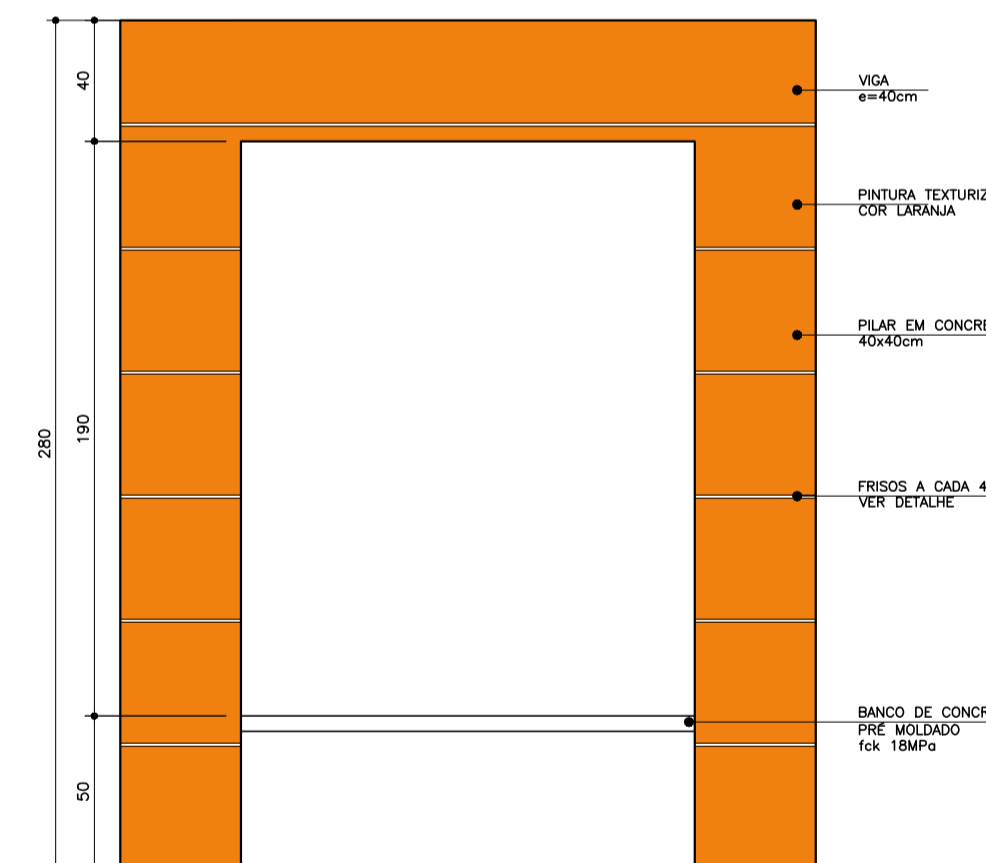
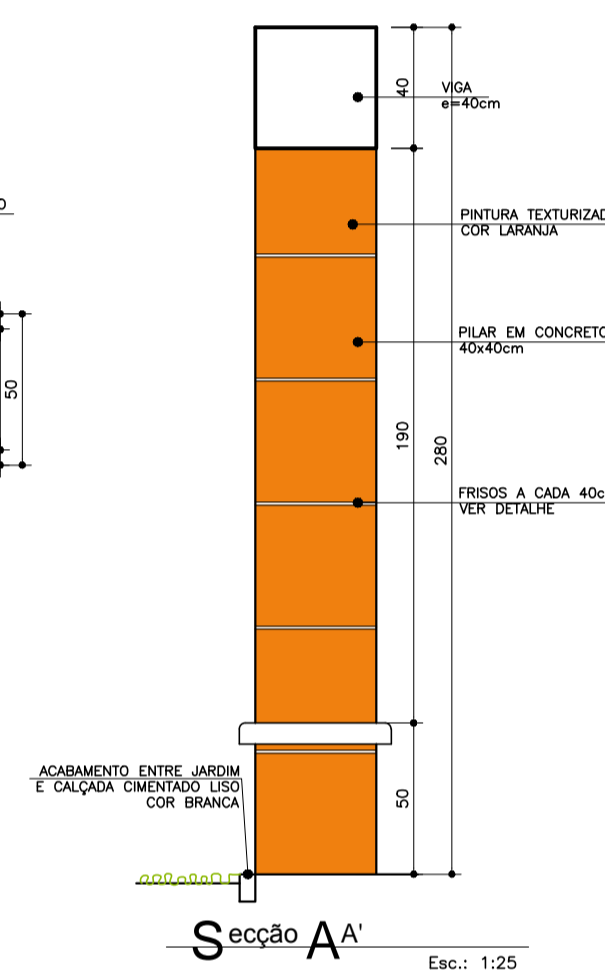
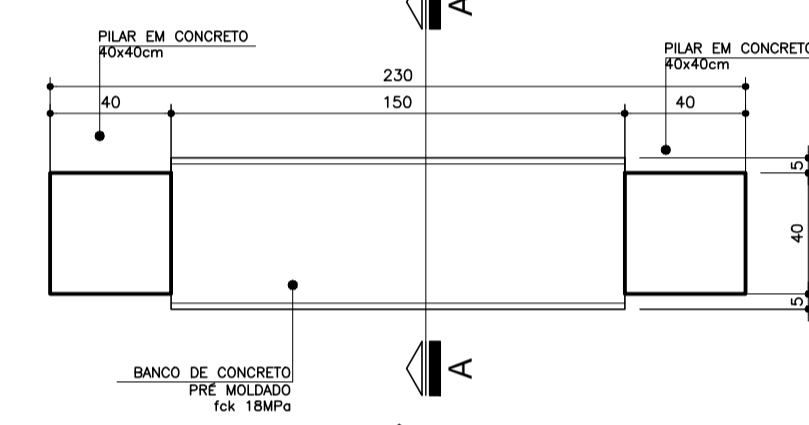

Dúvidas e sugestões pelo email: [plantarequalificaubs@saude.gov.br](mailto:plantarequalificaubs@saude.gov.br)  
Medidas em centímetros.  
O valor da cota prevalece ao da escala.

**O**BR: UBS-Unidade Básica de Saúde - Porte II  
**P**ROPRIEDÁRIO: Ministério da Saúde  
**A**UTOR: Detalhamento Bancos Externos  
**A**UTOR: Carlos Marchesi - CAU 61.789-9

DETALHE: 09  
CÓDIGO: DET. BANCO EXTERNO 3-1  
ESCALA: Indicada  
DATA: Agosto/2013  
DESENHO: Juliana

